

IAA Space Geodetic Software

I. Gayazov, V. Gubanov, S. Kurdubov, V. Suvorkin
O. Brattseva

*IAA RAS, Saint Petersburg, Russian Federation,
ipa@ipa.nw.ru*

- **Techniques:**
 - VLBI (IVS: 24h - weekly, Int - daily)
 - VLBI (Ru: 24h - weekly, 1h - daily)
 - GNSS (IGS, 24h, - daily)
 - SLR (ILRS, 96h - daily)
- **Software:**
 - VLBI: Quasar OCCAM/GROSS
 - GNSS: Grape
 - SLR: GROSS, Grape
 - Combining: SINCom

- Reduction parameters
 - Most calculations done according to the IERS Conventions (2010)
 - Various options
- Single and multi session estimations
- Estimation options
 - Various parameters can be estimated
 - Every parameters can be global, arc or stochastic
 - Every parameters can be estimated as polynomial trends
- Least Square Collocation method
 - Mean correlation function
 - Individual variance values for each station

- Global solution :
 - TRF
 - CRF
 - EOP
 - Coordinate Frames stability research, tidal effects research, etc.
- Daily EOP, sources positions and station coordinates NEQ matrices (SINEX format) for combining
- Ultra-rapid Ru-U processing (UT1)

- Processing strategy is in accordance to IGS and IERS recommendations
- Multi-group LSA technique
- Processing daily GNSS network phase and code measurements of GNSS satellites with 30s sample
- Multi-regime processing
- SINEX products output
- SLR processing (test mode)
- New version launched February 2014

Different combination of fixed and estimated parameters.

- PPP
- Global estimation (fixed stations) with following products:
 - EOP
 - Satellite parameters (r , v , solar pressure)
 - satellites and stations clock biases
 - Troposphere

Daily processing 32 satellites, 50 stations within IGS network, EOP results are provided to IERS:

- Satellites orbits compared to IGS: 25-60mm rms
- EOP, compared to IERS series:
 - 55 μs for pole motion coordinates
 - 13 μs for LOD
- Troposphere: 1.3 mm st.dev compared to IGS

- GROSS :
 - daily EOP data, is provided to IERS
 - Pole motion: st. dev 170 μ as
 - LOD: st.dev 25
- GRAPE SLR:
 - Determination of low-degree Geopotential coefficients

- Combined processing of different space geodesy observations
- Estimate EOPs and positions of stations
- Apply constraints
- Fix or pre-eliminate parameters
- Estimate station velocities
- Simple text user interface
- Competitive, powerful and easy-to-use tool

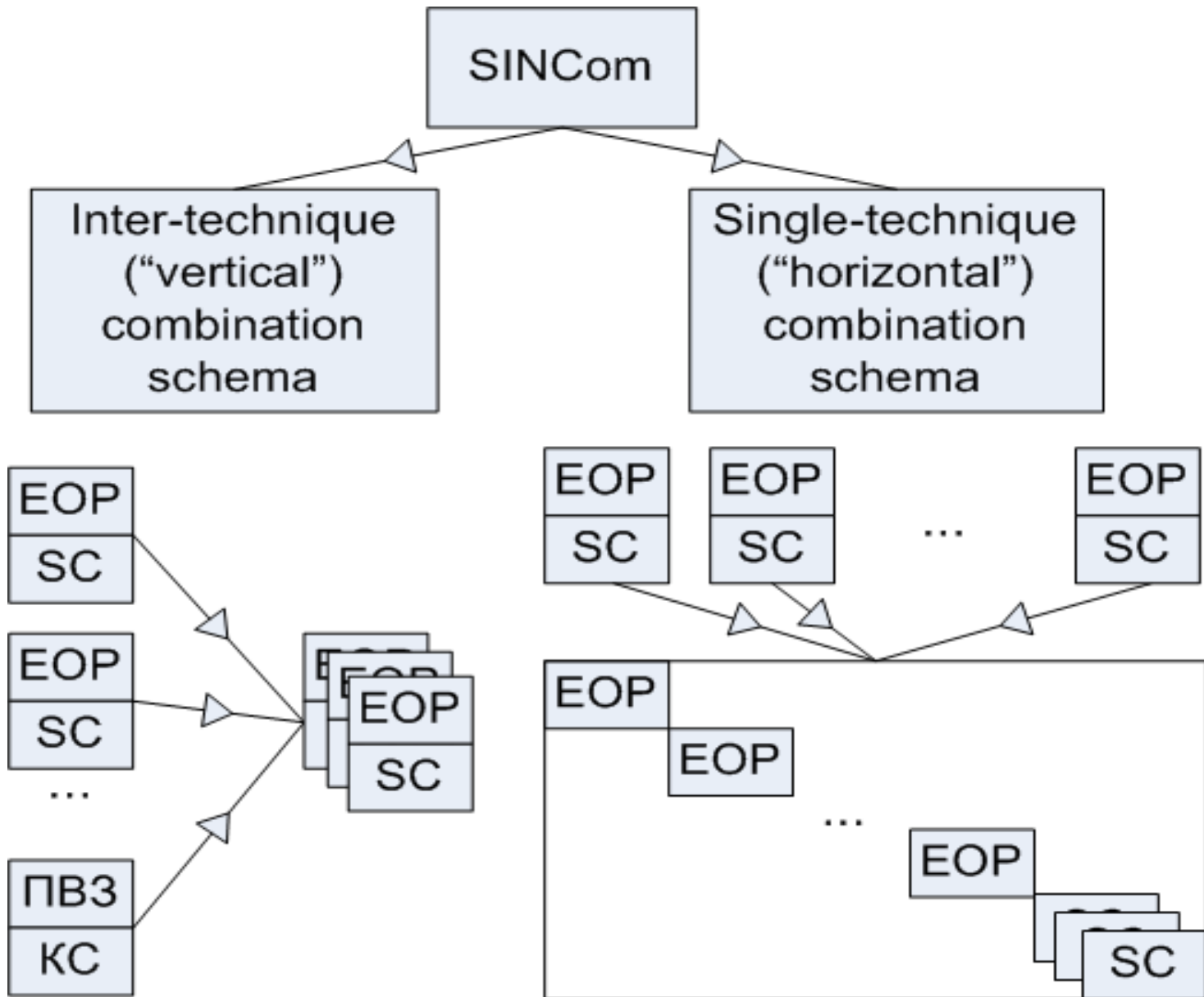

- The horizontal combination scheme was applied to the SINEX files got from SLR observations during 2012-2013 years. Coordinates of stations of the QUASAR network (Svetloe, Zelenchukskaya, Badary) and their velocities were estimated.

- Modernization of GNSS software
- Include SLR measurements to GRAPE
- Regular SINEX output and combined solutions including all techniques